



General presentation

PRECIA-MOLEN offers a range of simple and reliable stainless steel crane scales.

They are protected against dust and water according to index IP 65, and can be used equally well indoors and outdoors.

The range is composed of different models varying from 150 to 6 500 kg for Trade Use (ML) and from 150 kg to 25 000 kg for Non-Trade Use (HML).

Range

Model	Range	Increment ⁽ⁱ⁾	Trade use
MCW 150	150 kg	0.05 kg	●
MCW 300	300 kg	0.1 kg	●
MCW 600	600 kg	0.2 kg	●
MCW 1500	1 500 kg	0.5 kg	●
MCW 3000	3 000 kg	1 kg	●
MCWT 6	6 t	2 kg	●
MCWT 12	12 t	5 kg	×
MCWT 25	25 t	10 kg	×

(i) In Trade Use or Division in Non-Trade Use

All models are also available with a built-in printer.

The standard version is delivered with :

- a remote control,
- a rechargeable battery,
- a battery charger,
- a swivelling hook*.

* except models 12 and 25 t (option).

European conformity

- Directive 90/384/CEE relating to Weighing Instruments with Non-Automatic Operation
- Directive 89/336/CEE relating to Electromagnetic Compatibility
- Directive 73/23/CEE relating to Low Voltage equipment
- Directive 89/392/CEE relating to the instruments

Description

Hardware aspect

- IP65 stainless steel case (protection against dust and water)
- Leak tight keypad with 5 keys (Zero, Automatic tare, Functions, Print and ON/OFF)
- Large 25 mm backlit LCD display with excellent readability, even under poor lighting conditions and low temperatures
- Upper galvanized shackle and bottom swivelling hook as standard fittings*
- Protection against shocks and overloads (safety factor K = 5) :
 - Safe overload 200 %,
 - Ultimate overload 500 %.

Functions

- Function mode configurable as follows :
 - PEAK function (maximum value read),
 - HOLD function (block weight display),
 - Accumulated weighing total,
 - conversion lb/kg.
- Remote control :
 - 4 standard keys configurable by the customer,
 - distance : 8 m.
- Seal battery with almost 40 hours endurance.
- Configuration, calibration, digital filter and automatic stop programmable directly on the keypad or by remote control.

Physical characteristics

150 to 6 500 kg models

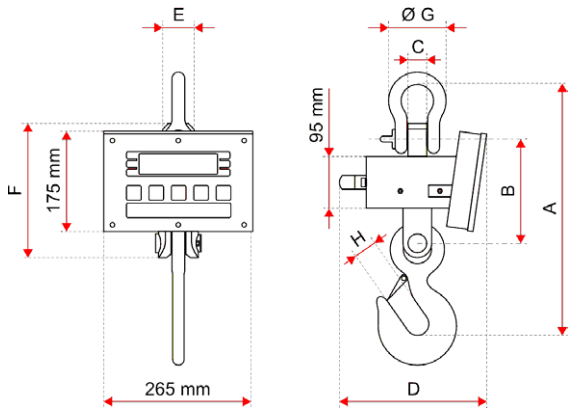

12 to 25 t models

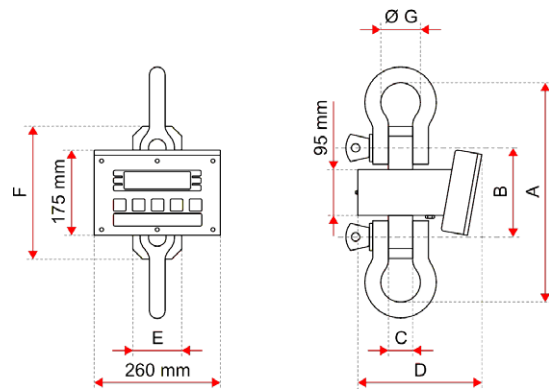

Model	Dimensions (mm)								Weight (kg)
	A	B	C	D	E	F	G	H	
MCW 150	321	160	24	260	45	200	43	27	8
MCW 300	321	160	24	260	45	200	43	27	8
MCW 600	321	160	24	260	45	200	43	27	8
MCW 1500	321	160	24	260	45	200	43	27	10
MCW 3000	450	187	34	260	55	240	58	45	15
MCWT 6	450	187	34	260	55	240	58	45	15

Model	Dimensions (mm)								Weight (kg)
	A	B	C	D	E	F	G		
MCWT 12	451	186	50	280	100	270	83	23	
MCWT 25	632	226	72	280	110	360	126	49	

Electrical characteristics

- Power supply by internal battery.
- Delivered with 230 V / 50 Hz charger

Environmental characteristics

- Operating temperature : -10 / + 40°C,

Options & Accessories

Swivelling hooks

- CG 15 : swivelling hook with 15 t safety latch.
- CG 22 : swivelling hook with 22 t safety latch.

Shackles*

- CA 2 2.5 t
- CA 4 4 t
- CA 8 8 t
- CA 15 15 t
- CA 30 30 t

Battery kit

MCWBK : spare battery kit for MCW including a battery and a charger.



Thermal printer

- Speed 50 mm / s
- Resolution 203 dpi
- Number of columns... 24 / 40
- Integrated battery
- Paper
 - Width 58 mm
 - Ø Reel 50 mm



* Shackles shall be sized for the load applied to the hook or a greater load.

You weighing specialist

Illustrations are not contractual. Precia-Molen reserves the right to modify at any time, without prior notice, the information contained in this leaflet.

Office and Factory
 P.O. Box 106 - 07000 Privas - FRANCE
 Tel. 33 (0) 475 664 600
 Fax 33 (0) 475 658 330
 E-MAIL webmaster@preciamolen.com
 RCS : 386 620 165 RCS Aubenas

